

## MIP-2300 EXTRA HD STEEL CUTTER

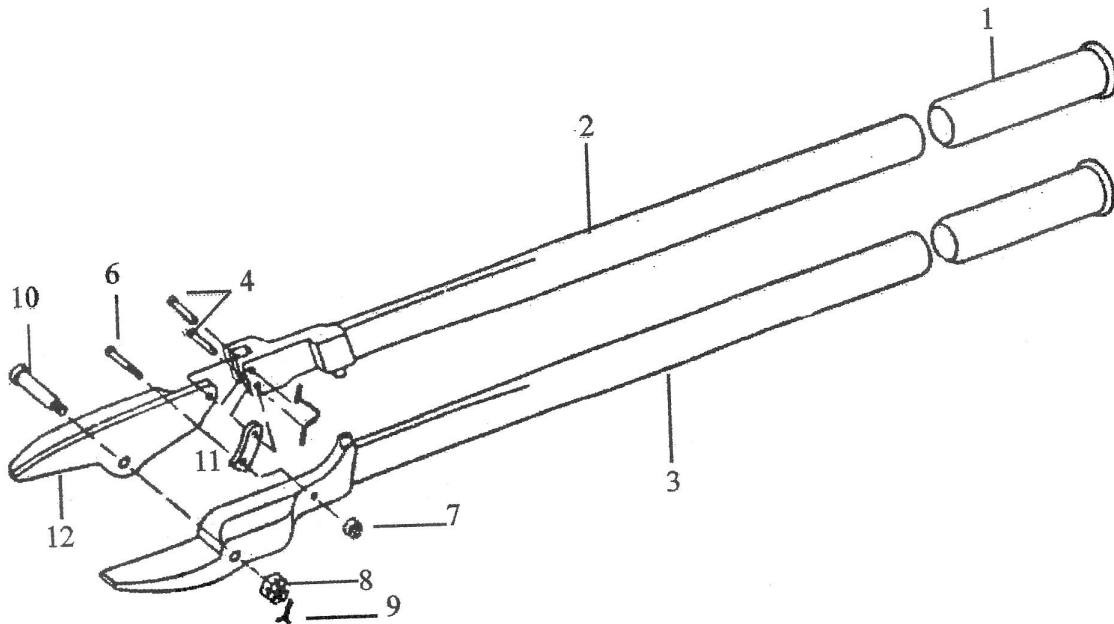

<b>KEY#</b>	<b>DESCRIPTION</b>	<b>QTY</b>	<b>PART#</b>
1	Handle Grip	2	M2300-1
2	Upper Handle Assembly	1	M2300-2
3	Lower Handle Assembly	1	M2300-3
4	Handle Pin	2	M2300-4
5	Retaining Ring	1	M2300-5
6	Link Pivot Bolt	1	M2300-6
7	Link Pivot Nut	1	M2300-7
8	Jaw Pivot Nut	1	M2300-8
9	Jaw Pivot Retaining Ring	1	M2300-9
10	Jaw Pivot Bolt	1	M2300-10
11	Toggle Link	1	M2300-11
12	Moving Blade	1	M2300-12

**Reference part number when ordering.  
Read and follow all operating & safety instructions on reverse.**

## MIP-2300 OPERATING INSTRUCTIONS

- Place one gloved hand on the strap and position yourself so that you are not in the path of the strapping.
- Cut the strap several inches away from your hand. The cut should be made so that the flying strap is too short to reach any part of the body.
- Strapping should be cut squarely, not at an angle, to avoid sharp strap edges.
- Immediately dispose of all strapping at avoid accidents and injury.

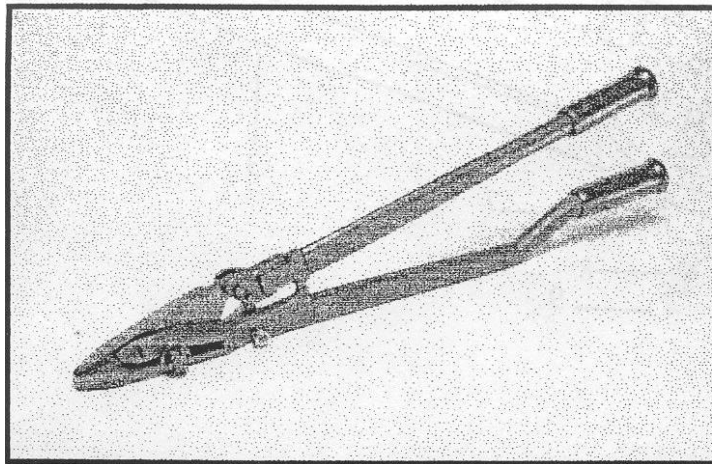

### SAFETY WARNINGS

- Always read the instructions. Only use equipment recommended for the strap. The MIP-2300 is recommended only for 3/4" .015 through 1-1/4" .050 gauge steel.
- Always wear adequate safety equipment for protection of your eyes, hands and body. Safety glasses must have side shields and conform to ANSI Standard Z-87.1. Wear protective safety gloves and clothing when handling strapping.
- Do not modify any tool. Modification can result in severe bodily injury. Keep fingers away from areas that can pinch or cut which are located primarily at the front of the tool. Unsafe conduct may result in blindness, severe laceration, amputation, or death.
- Injuries can be caused by excessive tensioning. Tension strap in moderation.
- To avoid injuries: Establish stable footing, Wear proper safety equipment as stated above, Never stand in front of strap, Use two hands to work sealer, Keep fingers away from all pinch points.
- Review joints made by your sealer. Make certain the notch or crimp is properly centered and completely formed.